



Features

- Economical ESD protective product to replace high charging plastic trash cans
- Static dissipative, low charging dissipative surface
- Constructed with double sides, triple ends, and double thickness bottom for greater durability (Items 37810, 37811)
- Steel reinforcing frame provides additional strength and durability
- Conductive plastic handles provide ease of handling along with reliable ESD control path-to-ground
- Identified with ESD Protective Symbol (Ref: ESD 8.1) (Items 37810, 37811)
- Easy assembly without the need for tape, glue, or staples
- ESD protective liners also available
- Impregnated corrugated material; greater durability than coated or printed material
- Static dissipative surface of 10E6 - 10E8 ohms*
- Buried shielding layer minimizes sloughing and rub-off contamination
- Made from 100% recycled material, and is 100% recyclable

SPECIFICATIONS

Properties

Electrostatic Decay
Surface Resistance

Surface Resistance, Low R.H. Cut-off
High-Voltage Discharge Resistance
Static Shielding
Charged Device Model (CDM) Safety
Current-Carrying Hazard

Corrosivity
Antistat Transfer
Water & Isopropyl Alcohol Extraction
Tests for Antistat Permanence
Sloughing Test

Recyclability
Biodegradability
Volume Conductivity

Shelf Life

Typical Values

0.01 seconds at 72°F and 11.8% R.H.
10E6 - 10E8 ohms/sq. after 11 days at 68°F and 12% R.H. for surface. 10E3 - 10E4 ohms/sq. for buried shielding layer
4% R.H.
Failure rate 0/5 (no oxide damage in five consecutive tests)
99.9% attenuation at 10kV; 99.6% attenuation at 30kV
RTT 10EG-10SP ohms
10E3 mA at 110V; 10E3 mA at 220V
Contains 1-3 ppm reducible sulfur
No transfer
Surface resistance 10E8 - 10E9 ohms/square at 74°F and 36% R.H.
Negligible surface damage at 10 cycles and <5% of surface damage at 200 cycles in Taber Abrasion Test.
No conductive particles abraded from surface
Complete recyclability of package
Biodegradation in or on moist soil
Conductivity from wall to wall as well as across surface to assure permanence of the antistatic property
Indefinite

Test Procedures/Method

FED-STD-101, Method 4046

ASTM D257
Rockwell International Test Report of December 20, 1991
Rockwell International Test Report of December 20, 1991
EIA 541, appendix E, capacitive probe test
Rockwell International Test Report of December 20, 1991
ESD from A to Z
FED-STD-101, Method 3005 for reducible sulfur
Rockwell International Test Report of January 8, 1992
Rockwell International Test Report of January 8, 1992

ASTM D4060 at 70 rpm with CS-17 abrasive-coated wheels and 1000 grams load
Rockwell International Test Report of January 8, 1992
Rockwell International Test Report of January 8, 1992

Rockwell International Test Report of January 8, 1992



Made in America

Protektive Pak® ESD Trash Receptacle

PROTEKTIVE PAK
13520 MONTE VISTA AVENUE, CHINO, CA 91710
PHONE (909) 627-2578, FAX (909) 363-7331
ProtektivePak.com

DRAWING NUMBER
37810

DATE:
July 2007

PROTEKTIVE PAK

Bottom Folding Instructions

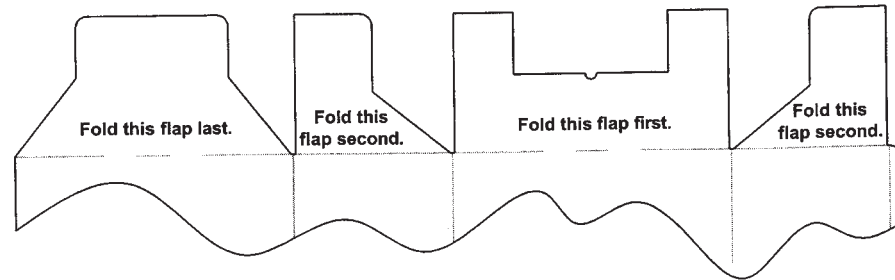

Wire Assembly Instructions

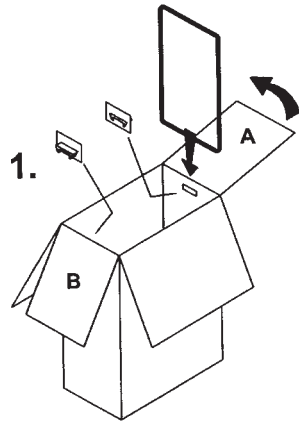

1. Insert handles before folding up box. Place shorter dimension of wire on crease where flap A & box meet.

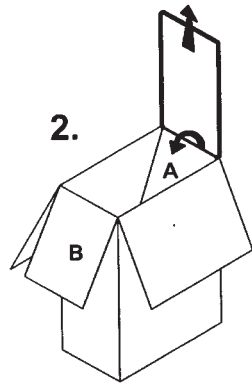

2. Insert flap A into wire. Fold flap A over short dimension of wire & completely into box while pulling the wire up. Make sure wire is within corner notches of flap.

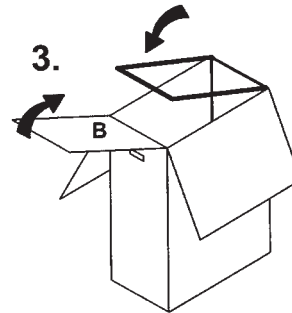

3. Bring down the wire to the other side of the box and fold over flap B. Check to make sure that the wire is at the top of the box tucked under the flaps.

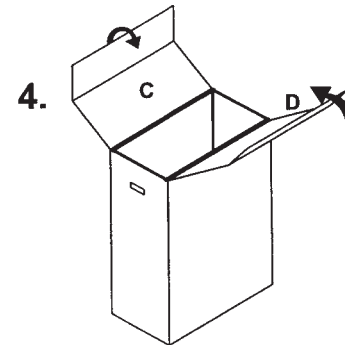

4. Fold flaps C & D at their middle creases and then fold them down into the box.

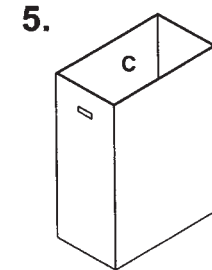

5. Make sure all flaps interlock with each other.

Item	Description (L x W x D)
37810	Trash Receptacle 13-1/2 x 12 x 13-1/4, 9 gal., with wire frame and handles
37811	Trash Receptacle 13-1/2 x 12 x 13-1/4, 9 gal., receptacle only
37812	Trash Receptacle 22-7/8 x 12-7/8 x 32, 40 gal., with wire frame and handles
37813	Trash Receptacle 22-7/8 x 12-7/8 x 32, 40 gal., receptacle only
37820	Trash Liner/ 10 gal. 26 x 24, 1.5 mil thickness
37821	Trash Liner/ 55 gal. 22 x 16 x 58, 1.5 mil thickness

"It should be understood that any object, item, material or person could be a source of static electricity in the work environment. Removal of unnecessary nonconductors, replacing nonconductive materials with dissipative or conductive materials and grounding all conductors are the principle methods of controlling static electricity in the workplace, regardless of the activity." (ESD Handbook TR 20.20 section 2.4)